

Continuous Motion Shrink Wrapper

nVenia's ARPAC Brand EXTREME XA models excel in a wide variety of applications. These pneumatically driven wrapping systems are designed to increase productivity, reduce wear and tear on parts, and eliminate the waste of time and energy by using a continuous motion design with a smooth, fast, and unbroken flow. With its superior design, the XA models are more reliable, require less maintenance, use less film and energy, and provide superior film tension for a better more consistent package. Additionally, the XA continuous motion wrappers will typically require 2-4" less film width than automatic L-sealers, intermittent motion wrappers, or any wrapper where the film path runs under the infeed conveyor.

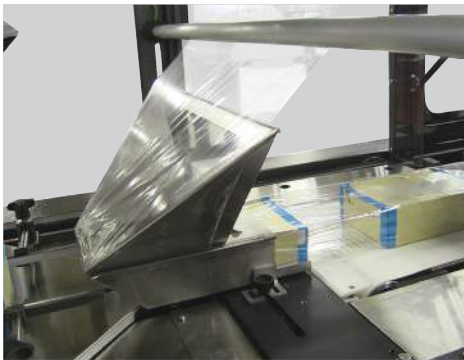

APPLICATIONS

- Automotive
- Beverage
- Building Supplies
- Consumer Goods
- Contract Packaging
- Food
- Health & Beauty
- Material Handling
- Printing & Publishing

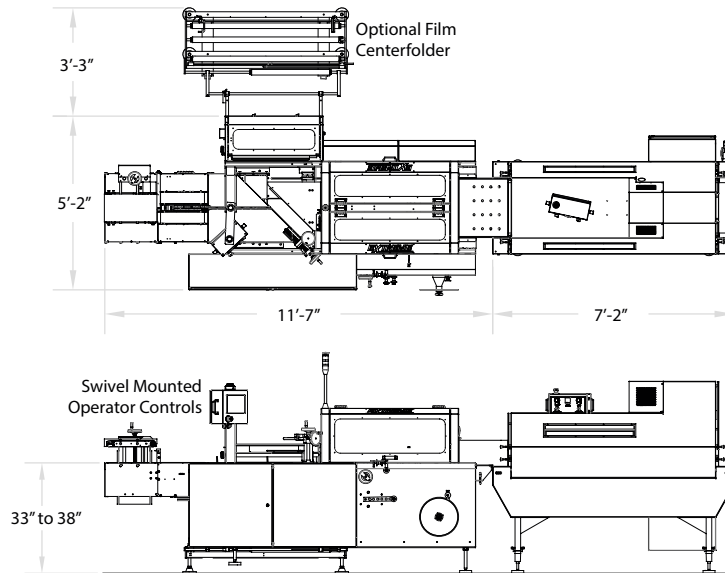

Layout with tunnel shown, final layout may vary.

FEATURES

- Heavy-duty construction for high durability and 24/7 operation
- Seal bars with multi-zone heater design for strong consistent seals
- Direct drive motors eliminate chains, sprockets, tensioners and the need for lubrication or any maintenance in those areas
- Easy clean side seal does not use any back up wheels, rubber rollers or separate cutting devices that require maintenance or replacement
- Color touchscreen on swivel allows two sided operation
- Tool-less changeover decreases maintenance
- Large gull wing doors allow easy access to major machine assemblies for periodic cleaning and inspection
- Powered scrap winder with dancer bar control and film break detect

OPTIONS

- Multiple frame and cross seal sizes
- Standard or custom infeeds for almost any application
- Powered product bypass
- Single or dual roll film centerfolders
- Stainless steel construction

SPECIFICATIONS

- Speed: 75 cycles per minute
- Electrical power requirements: 240 VAC, 3 Ph, 60 Hz
- Air requirements: 5 SCFM at 80 psi

PACKAGE SIZE RANGE

- XA (Side Seal) - 18" W x 8" H
- XAT (Top Seal) - 8" W x 12" H
- XAL (Lap Seal) - 18" W x 8" H

All models are capable of infinite length.

FILM

- Max. roll diameter: 16"
- 30 to 75 gauge polyolefin or 1 to 3 mil low density polyethylene
- Type: LDPE, polyolefin
- Other specifications: up to 52" flat or 25" centerfold