

Automated Bagging System for Powders

- Fully Integrated, High Speed, High Volume Bag Handling
- Provided with Two Station Auger Filling System - Up to 6 Bags Per Minute

The Model 3603 picks, places and opens the empty bag at the first 'Bulk' auger fill station where it is volumetrically filled to just below target weight. The bag is then indexed to the second 'Dribble' auger fill station where it is accurately weighed and topped off to target weight.

The Model 3603 is integrated with an auger filling system and is capable of handling gusseted, multi-wall open mouth paper, and paper pinch bags.



Shown with Fischbein Brand PBC 6000 Sealer
and Optional Conveyors

APPLICATIONS

- Bakery Mixes
- Powdered Dairy Products
- And more...
- Flour
- Seasonings
- Food Ingredients/Additives
- Spices

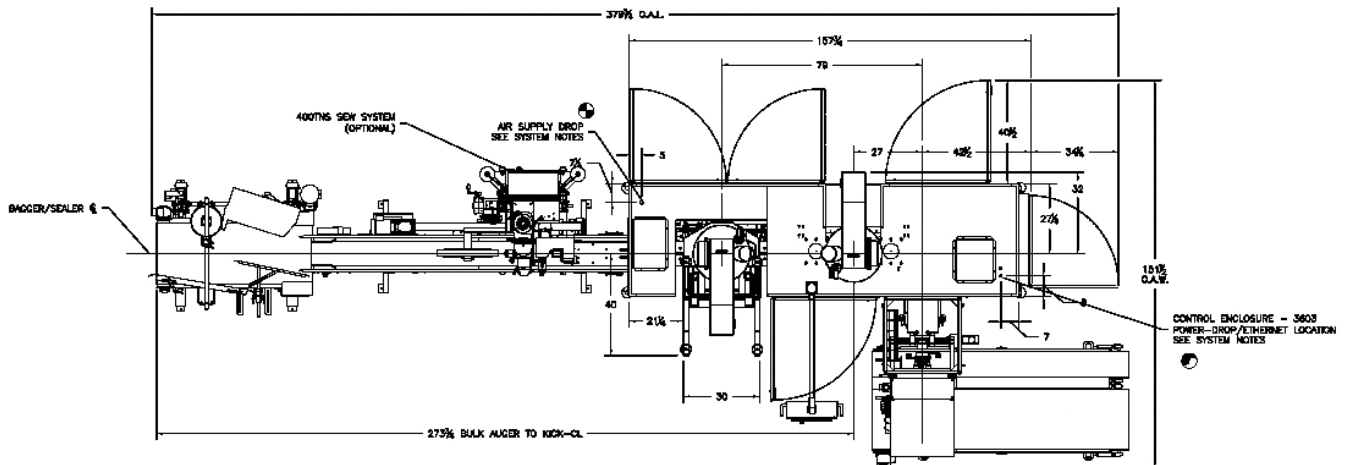

FEATURES

Bag Types

- Processes a variety of pillow or gusseted bags, including multi-wall paper.

Fast Product Changeover

- Product change-over is fast, easy, and safe thanks to advanced touch screen controls and motorized adjustments.

Auto Bag Correction

- Auto bag index correction ensures the bag is centered under the spout prior to filling.

No Bag - No Dump Feature

- The “no bag-no dump” feature prevents the machine from releasing product unless the bag is centered correctly, making for minimal product spills.

OPTIONS

- Integrated sealing conveyor
- Extended bag feed conveyor
- Tagger infeed assembly
- Special anti-corrosion package
- 575 VAC
- Automated tilt tray adjustments
- Network router

SPECIFICATIONS

Dimensions:

- L 158" (401 cm), D 111" (282 cm), H 88-1/4" (224cm)

Note: standard door swing is 39" (99 cm) additional width and electrical enclosure requires 34" (86 cm) in length at rear of machine

Speed:

- Up to 6 bags per minute, product and bag size dependent

Electric (NEMA 12):

- 460 VAC, 3 PH, 60 Hz

Air:

- 10 cfm @ 60 PSI

BAGS

Bag Types:

- Multi-wall paper, laminated woven polypropylene

Bag Thickness:

- Minimum 6 mil

Bag Sizes Min:

- 12"W x 18"L (30.5 cm x 45.7 cm) minimum
- 20" W x 36" L (50.8 cm x 91.4 cm) maximum

Free Bag Top:

- Minimum 7 in (17.8 cm)