

Produce Weighing and Bagging System

Set the standard in produce packaging weight accuracy, speed and bottom line savings. This advanced, highly dependable system automatically dispenses from 20 to 100 pounds of potatoes, onions, carrots, parsnips, walnuts and similar produce into cartons or paper, mesh, burlap and poly bags. Up to 400 50 pound bags-per-hour is typical.

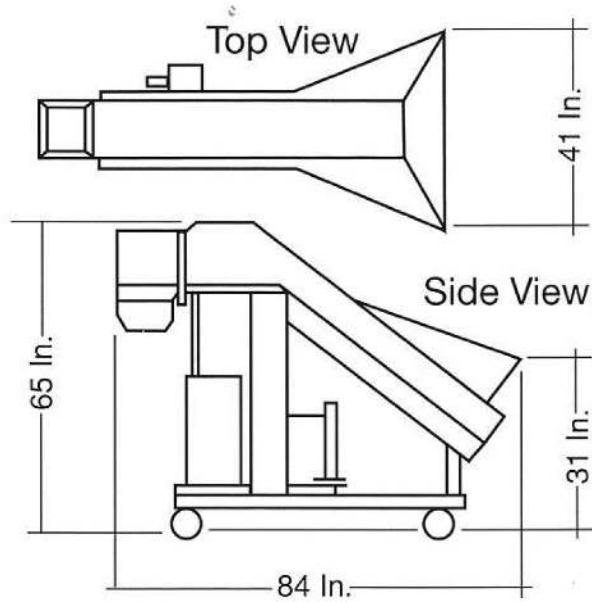



FEATURES

- 20 lb to 100 lb fill weights
- Up to 400 50 lb bags per hour
- Heavy duty all steel construction
- Automatic bag clamp
- Casters for portability
- Self contained feeding and filling unit
- Box filling option

OPTIONS

- 20 lb to 25 lb (44 kg to 55 kg) bagging head
- 90 degree bagging head bracket
- Box loading platform
- Jaw size reducers
- Extra weight box

MODEL 355 PRODUCE BAGGING AND WEIGHING DELIVERY RATES

Bag Wt.	Bags Per Hr.	Lbs Per Min.	Tons Per Hr..	Per 8 Hr. Day
25	480/600	200/250	6.0/7.5	3840/4800
51	420/480	357/408	10.7/12.2	3360/3840
75	260/320	329/405	9.9/12.2	2080/2560
102	250/300	425/510	12.8/15.3	2000/2400

SPECIFICATIONS

- Dimensions: L 103 in (262 cm), D 66 in (103 cm), H 144 in (366 cm)
- Product discharge height: Manual: 48 in (122 cm), Automated: 57 in (145 cm)
- Conveyor: 20 in (51 cm) wide
- Electric: 460VAC, 3 PH, 60 Hz
- Air: 5 cfm @ 80 PSI
- Operating Temperature: Min. 40 degrees Fahrenheit (4.5 degrees Celsius)